

# IFO2225-873

22" WSXGA TFT Fanless Super Slim Touch Panel Computer with Intel® Core™ i7/i5/i3 & Celeron® Processor

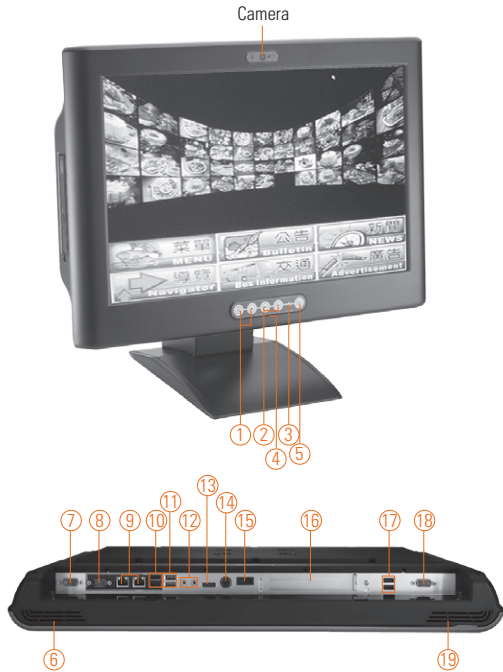

- |                              |                             |                     |
|------------------------------|-----------------------------|---------------------|
| 1. Brightness adjust buttons | 7. COM 2 (RS-232)           | 13. DisplayPort     |
| 2. Volume adjust buttons     | 8. COM 1 (RS-232/422/485)   | 14. Power connector |
| 3. Power LED                 | 9. Gigabit LAN x 2          | 15. Power switch    |
| 4. MIC                       | 10. USB 2.0 x 2             | 16. PCI or PCIe x 4 |
| 5. Power switch              | 11. USB 3.0 x 2             | 17. USB 2.0 x 2     |
| 6. Speaker (R)               | 12. Audio (Line-out/Mic-in) | 18. COM 3 (RS-232)  |
|                              |                             | 19. Speaker (L)     |



## Introduction

The IFO2225-873 is a slim panel computer equipped with a 22-inch 250 nits high brightness WSXGA LCD display that supports an 3rd generation Intel® Core™ i7/i5/i3 & Celeron® processor up to 35 W with Intel® QM77 chipset. The Intel® HD Graphics 4000/2500 engine with DX11 support is built into the chipset to provide fast graphics performance. The panel PC also supports DualView and multiple I/O options including 4 USB 2.0 and 3 RS-232 ports. The built-in 5 mega pixels camera and microphone/speakers can provide a solution for VoIP and remote monitoring. The IFO2225-873 also supports an antenna for wireless (802.11 b/g/n) connection. Its dual Gigabit Ethernet ports provide high speed Ethernet as well as a high reliable redundancy host connection. This robust unit is designed to be work under minimal noise levels, low power consumption, high reliability and while maintaining efficient performance. Its excellent industrial design (ID) and user friendly interface design make it an ideal solution best suited for infotainment, advertising messaging, and other digital signage applications.

## Features

- 22" (250 nits) WSXGA TFT LCD
- Socket rPGA988B 3rd generation Intel® Core™ i7/i5/i3 (Ivy Bridge) & Celeron® processor
- Intel® QM77 chipset
- USB 3.0 supported
- Water/dust-proof design (front bezel: IP65, full enclosure: IPX1)
- 1 PCI or PCIe x4 expansion slot and 2 PCIe Mini Card slots
- Optional Bluetooth/Wi-Fi (802.11 a/b/g/n)
- Built-in 5 mega pixels camera
- Supports optional Wall mount, VESA arm and desktop stand



▲ Rear view

## Specifications

Front Bezel	Plastic ABS	
LCD Panel	Display Type	22" WSXGA TFT
	Brightness (cd/m <sup>2</sup> )	250 nits
	Resolution	1680 x 1050
	Viewing Angle (H/V)	178°/178°
Main System	CPU	Socket rPGA988B 3rd generation Intel® Core™ i7/i5/i3 & Celeron® processor, TDP up to 35W
	Chipset	Intel® QM77
	System Memory	2 x 204-pin DDR3 SO-DIMM max. up to 16 GB
	BIOS	AMI UEFI BIOS with OA 3.0 built
	Storage	1 x 2.5" SATA HDD 1 x mSATA SSD (optional)
	Optical Drive	1 x Super Multi drive (optional)
	Watchdog Timer	255 levels, 0-255 sec.
	Onboard Graphics	Intel® HD Graphic

Архангельск (8182)63-90-72  
Астана +7(7172)727-132  
Белгород (4722)40-23-64  
Брянск (4832)59-03-52  
Владивосток (423)249-28-31  
Волгоград (844)278-03-48  
Вологда (8172)26-41-59  
Воронеж (473)204-51-73  
Екатеринбург (343)384-55-89  
Иваново (4932)77-34-06  
Ижевск (3412)26-03-58  
Казань (843)206-01-48

Калининград (4012)72-03-81  
Калуга (4842)92-23-67  
Кемерово (3842)65-04-62  
Киров (8332)68-02-04  
Краснодар (861)203-40-90  
Красноярск (391)204-63-61  
Курск (4712)77-13-04  
Липецк (4742)52-20-81  
Магнитогорск (3519)55-03-13  
Москва (495)268-04-70  
Мурманск (8152)59-64-93  
Набережные Челны (8552)20-53-41

Нижний Новгород (831)429-08-12  
Новокузнецк (3843)20-46-81  
Новосибирск (383)227-86-73  
Орел (4862)44-53-42  
Оренбург (3532)37-68-04  
Пенза (8412)22-31-16  
Пермь (342)205-81-47  
Ростов-на-Дону (863)308-18-15  
Рязань (4912)46-61-64  
Самара (846)206-03-16  
Санкт-Петербург (812)309-46-40  
Саратов (845)249-38-78

Смоленск (4812)29-41-54  
Сочи (862)225-72-31  
Ставрополь (8652)20-65-13  
Тверь (4822)63-31-35  
Томск (3822)98-41-53  
Тула (4872)74-02-29  
Тюмень (3452)66-21-18  
Ульяновск (8422)24-23-59  
Уфа (347)229-48-12  
Челябинск (351)202-03-61  
Череповец (8202)49-02-64  
Ярославль (4852)69-52-93



## Specifications

I/O Connector	2 x RS-232 (COM 2/3) 1 x RS-232/422/485 2 x 10/100/1000Mbps Ethernet 4 x USB 2.0 2 x USB 3.0 1 x Audio (Line-out) 1 x Audio (Mic-in) 1 x DisplayPort
Expansion Interface	1 x PCI or 1 x PCIe x4 slot 2 x PCIe Mini Card slot (optional)
Speaker	2 x 2W
Camera	1 x 5M pixels camera
Touchscreen	5-wire resistive type
Function Key	LCD brightness up/down, audio volume up/down, power on/off
Power Supply	External 19VDC or 24VDC with AC/DC power adapter
Dimensions	573.5 mm (22.57") (W) x 75.9 mm (2.98") (D) x 398.9 mm (15.7") (H)
Packing Dimensions	730 mm (28.74") (W) x 240 mm (9.45") (D) x 650 mm (25.59") (H)
Weight (net/gross)	10.58 kg (23.32 lb)/ 15.16 kg (33.42 lb)
Environment	Operating temperature: 0°C ~ +40°C (+32°F ~ +104°F) Storage temperature: 0°C ~ +40°C (+32°F ~ +104°F) Relative humidity: 20% ~ 90% @ 40°C; non-condensing
Certificate	CE

## Ordering Information

IF02225-873-NP-DRW	22" WSXGA fanless touch panel computer with 3rd generation Intel® Core™ processor, 5-wire resistive touch screen, super multi drive and AC-DC 120W power adapter (screw type connector)
IF02225-873-NP w/o DRW	22" WSXGA fanless touch panel computer with 3rd generation Intel® Core™ processor, 5-wire resistive touch screen and AC-DC 120W power adapter (screw type connector)

\* Specification and certifications are based on options and may vary.  
\*\*Super Multi drive includes DVD-R, DVD-RW and DVD-RAM.

## Optional Accessories

E202003330	VM-101 VESA ARM (clamp type)
E202003329	VM-105 VESA ARM (wall mount type)
E222175103	22" stand kit

## Optional OS Installation

- Windows® XP
- Windows® 7
- Windows® 8.1
- WEBS

## Dimensions

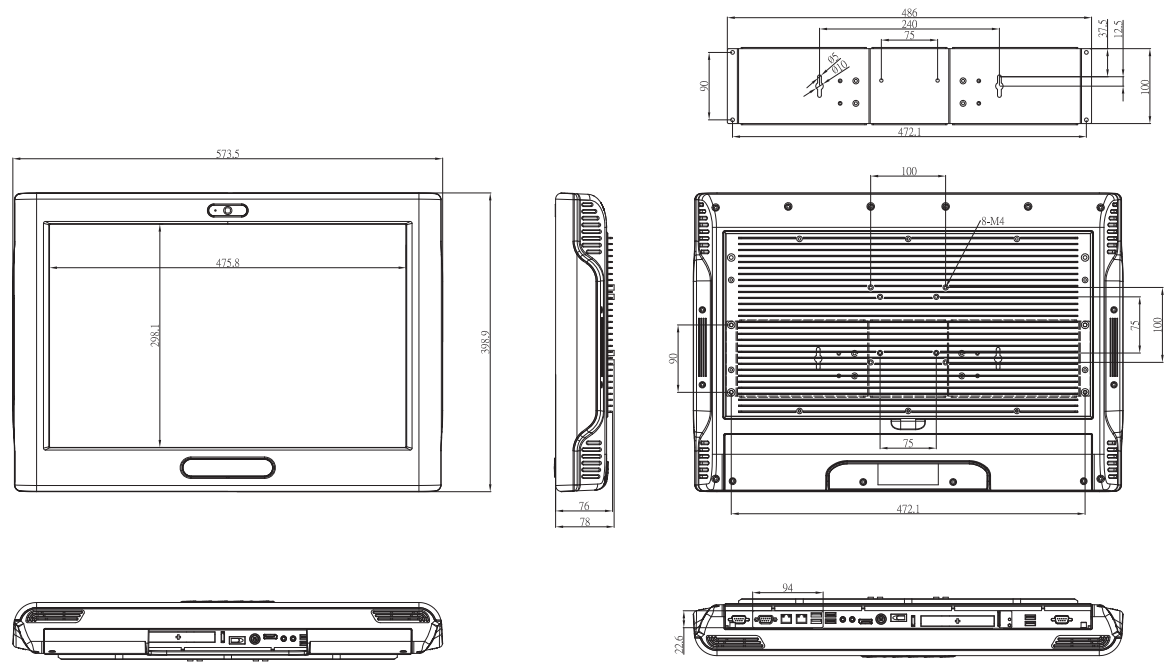

# IFO2175-873

17" SXGA TFT Fanless Super Slim Touch Panel Computer with 3rd Generation Intel® Core™ i7/i5/i3 & Celeron® Processor

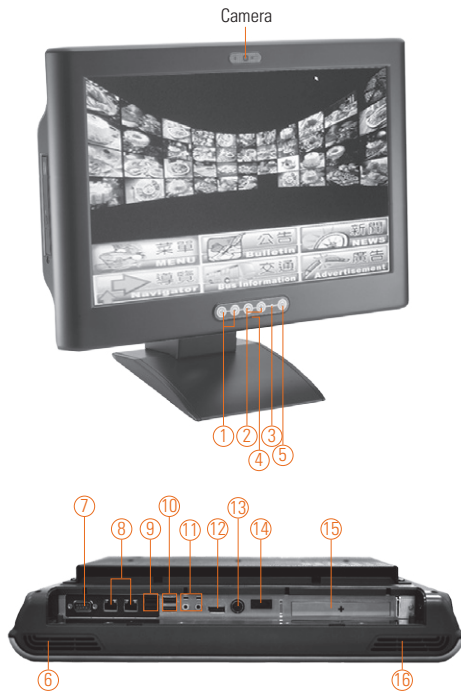

- |                              |                              |                      |
|------------------------------|------------------------------|----------------------|
| 1. Brightness Adjust buttons | 7. COM 1<br>(RS-232/422/485) | 13. Power connector  |
| 2. Volume adjust buttons     | 8. Gigabit LAN x 2           | 14. Power switch     |
| 3. Power LED                 | 9. USB 2.0 x 2               | 15. PCI or PCIe slot |
| 4. MIC                       | 10. USB 3.0 x 2              | 16. Speaker (L)      |
| 5. Power on/off button       | 11. Audio (Line-out/Mic-in)  |                      |
| 6. Speaker (R)               | 12. DisplayPort              |                      |



## Introduction

The IFO2175-873 is a slim panel computer equipped with a 17-inch 350 nits high brightness SXGA LCD display that supports a 3rd generation Intel® Core™ i7/i5/i3 & Celeron® processors up to 35W with Intel® QM77 chipset. The Intel® HD Graphics engine with DX11 support is built into the chipset to provide fast graphics performance. The panel PC also supports DualView and multiple I/O options including 4 USB and 1 RS-232/422/485 ports. The built-in 5 mega pixels camera and microphone/speakers can provide a solution for VoIP and remote monitoring. The IFO2175-873 also supports an antenna for wireless (802.11 b/g/n) connection. Its dual Gigabit Ethernet ports provide high speed Ethernet as well as a high reliable redundancy host connection. This robust unit is designed to be work under minimal noise levels, low power consumption, high reliability and while maintaining efficient performance. Its excellent industrial design (ID) and user friendly interface design make it an ideal solution best suited for infotainment, advertising messaging, and other digital signage applications.

### Water/dust-proof design for entire system: IPX1

The IPX1-rated water/dust-proof housing protects the entire system from outside damage caused by water drip damage while installed at public or enclosed environments. Its unique design improves system stability while saving time and money on maintenance costs and re-installation time.

## Features

- 17" (350 nits) SXGA TFT LCD
- Socket rPGA988B 3rd generation Intel® Core™ i7/i5/i3 (Ivy Bridge) & Celeron® processor
- Intel® QM77 chipset
- USB 3.0 supported
- Water/dust-proof design (front bezel: IP65, full enclosure: IPX1)
- Optional one PCI or PCIe x4 expansion slot
- Optional Bluetooth/Wi-Fi (802.11 b/g/n)
- Built-in 5 mega pixels camera
- Supports optional wall mount, VESA arm and desktop stand

## Specifications

Front Bezel	Plastic ABS	
LCD Panel	Display Type	17" SXGA TFT LCD
	Brightness (cd/m <sup>2</sup> )	350 nits
	Resolution	1280 x 1024
	Viewing Angle (H/V)	178°/178°
Main System	CPU	Socket rPGA988B 3rd generation Intel® Core™ i7/i5/i3 & Celeron® processor, TDP up to 35W
	Chipset	Intel® QM77
	System Memory	2 x 204-pin DDR3 SO-DIMM max. up to 16 GB
	BIOS	AMI UEFI BIOS with OA 3.0 built
	Storage	1 x 2.5" SATA HDD
		1 x mSATA
	Optical Drive	1 x Super Multi drive (optional)
	Watchdog Timer	255 levels, 0-255 sec.
	Onboard Graphics	Intel® HD Graphic

## Specifications

I/O Connector	1 x RS-232/422/485 (isolated 4KV) 2 x 10/100/1000Mbps Ethernet 2 x USB 2.0 (isolated 4KV) 2 x USB 3.0 1 x Audio (Line-out) 1 x Audio (Mic-in) 1 x DisplayPort
Expansion Interface	1 x PCI or 1 x PCIe x4 slot (optional) 2 x PCIe Mini Card slot
Speaker	2 x 2W
Camera	1 x 5M pixels camera
Touchscreen	5-wire resistive type
Function Key	LCD brightness up/down, audio volume up/down, power on/off
Power Supply	External 19VDC or 24VDC with AC/DC medical grade power adapter
Dimensions	438 mm (17.24") (W) x 76.5 mm (3.01") (D) x 376.4 mm (14.81") (H)
Packing Dimensions	610 mm (24.02") (W) x 260 mm (10.24") (D) x 590 mm (23.23") (H)
Weight (net/gross)	8.0 kg (17.63 lb)/ 11.9 kg (26.23 lb)
Environment	Operating temperature: 0°C ~ +40°C (+32°F ~ +104°F) Storage temperature: 0°C ~ +40°C (+32°F ~ +104°F) Relative humidity: 20% ~ 90% @ 40°C; non-condensing
Certificate	CE

## Ordering Information

IF02175-873-NP-DRW	17" SXGA fanless touch panel computer with 3rd generation Intel® Core™ processor, 5-wire resistive touch screen, super multi drive and AC-DC 120W power adapter (screw type connector)
IF02175-873-NP w/o DRW	17" SXGA fanless touch panel computer with 3rd generation Intel® Core™ processor, 5-wire resistive touch screen and AC-DC 120W power adapter (screw type connector)

\* Specification and certifications are based on options and may vary.  
\*\*Super Multi drive includes DVD-R, DVD-RW and DVD-RAM.

## Optional Accessories

E202003330	VM-101 VESA ARM (clamp type)
E202003329	VM-105 VESA ARM (wall mount type)
E228170100	17" stand kit

## Optional OS Installation

Windows® XP
Windows® 7
Windows® 8.1
WEBS

## Dimensions

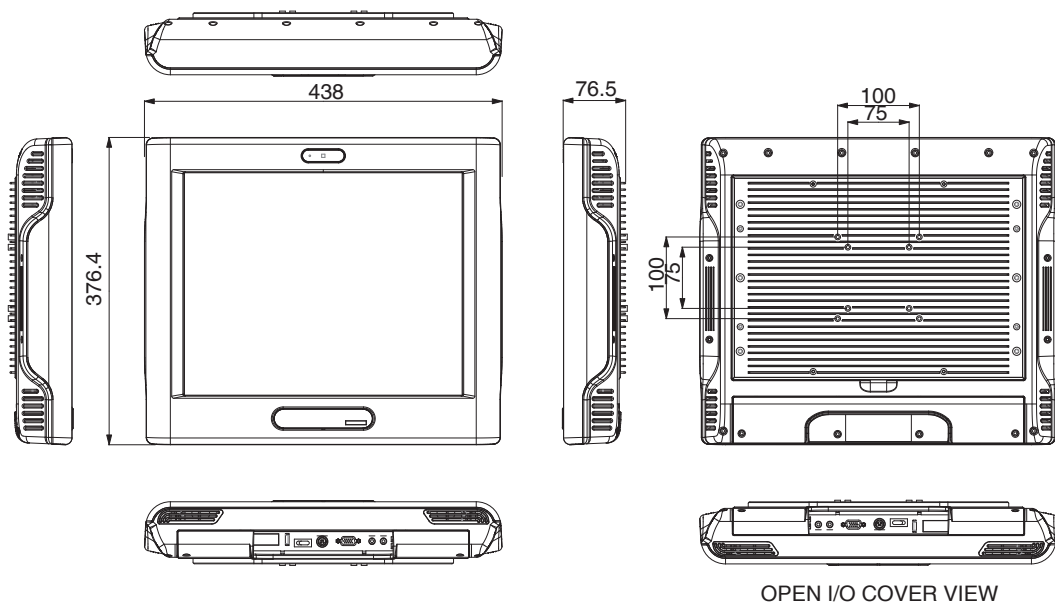

Архангельск (8182)63-90-72  
Астана +7(7172)727-132  
Белгород (4722)40-23-64  
Брянск (4832)59-03-52  
Владивосток (423)249-28-31  
Волгоград (844)278-03-48  
Вологда (8172)26-41-59  
Воронеж (473)204-51-73  
Екатеринбург (343)384-55-89  
Иваново (4932)77-34-06  
Ижевск (3412)26-03-58  
Казань (843)206-01-48

Калининград (4012)72-03-81  
Калуга (4842)92-23-67  
Кемерово (3842)65-04-62  
Киров (8332)68-02-04  
Краснодар (861)203-40-90  
Красноярск (391)204-63-61  
Курск (4712)77-13-04  
Липецк (4742)52-20-81  
Магнитогорск (3519)55-03-13  
Москва (495)268-04-70  
Мурманск (8152)59-64-93  
Набережные Челны (8552)20-53-41

Нижний Новгород (831)429-08-12  
Новокузнецк (3843)20-46-81  
Новосибирск (383)227-86-73  
Орел (4862)44-53-42  
Оренбург (3532)37-68-04  
Пенза (8412)22-31-16  
Пермь (342)205-81-47  
Ростов-на-Дону (863)308-18-15  
Рязань (4912)46-61-64  
Самара (846)206-03-16  
Санкт-Петербург (812)309-46-40  
Саратов (845)249-38-78

Смоленск (4812)29-41-54  
Сочи (862)225-72-31  
Ставрополь (8652)20-65-13  
Тверь (4822)63-31-35  
Томск (3822)98-41-53  
Тула (4872)74-02-29  
Тюмень (3452)66-21-18  
Ульяновск (8422)24-23-59  
Уфа (347)229-48-12  
Челябинск (351)202-03-61  
Череповец (8202)49-02-64  
Ярославль (4852)69-52-93